



Oficinas/Fábrica - Office/Factory:
Josep Ros i Ros, 57 - Pol. Ind. La Clota
08740 Sant Andreu de la Barca
(Barcelona) Spain

Sales/Comercial
Tel.: +34 902 463 636
+34 932 656 228
Fax: +34 932 463 071

Accounts/Administ.
Purchasing/Compras
Tel.: +34 932 463 636
Fax: +34 932 463 071

Export Dep./Dep. Exportación
Tel.: +34 932 650 246
Fax: +34 932 463 071
VAT n.º ESA 08110181

e-mail: admin@resistenciastope.com / www.resistenciastope.com

RAILWAY POINTS HEATING SYSTEMS

TOPE tubular heating-element, with flat-oval profile, is working after the principle of electric resistant heating, with specific heating power of roundabout 300 W/m. The heating elements are of protection class IP 65.

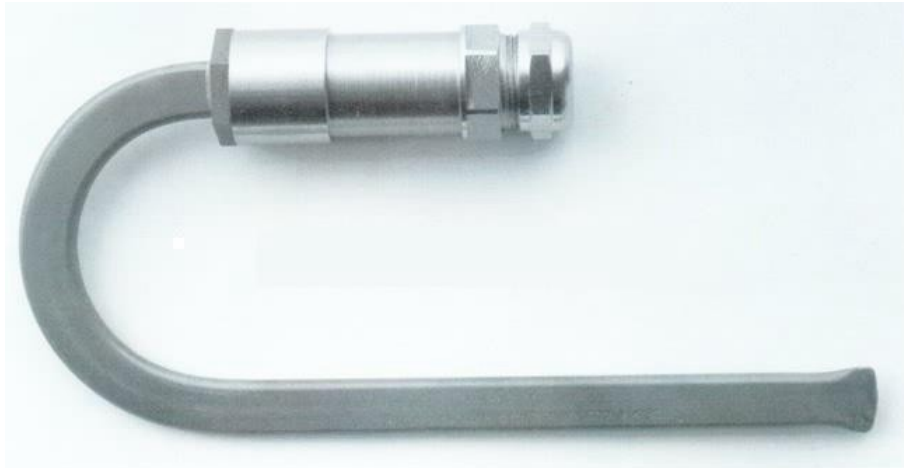

TOPE heating elements are mounted on the base of the rail by means of special clamp straps made of corrosion-resistant chrome-nickel steel. The chosen surface pressure guarantees an optimum heat transfer. Beyond that it allows an unavoidable linear extension of the heating elements without limitation. The strong fixing of the connecting heads prevents the heating elements from creeping (see description below).

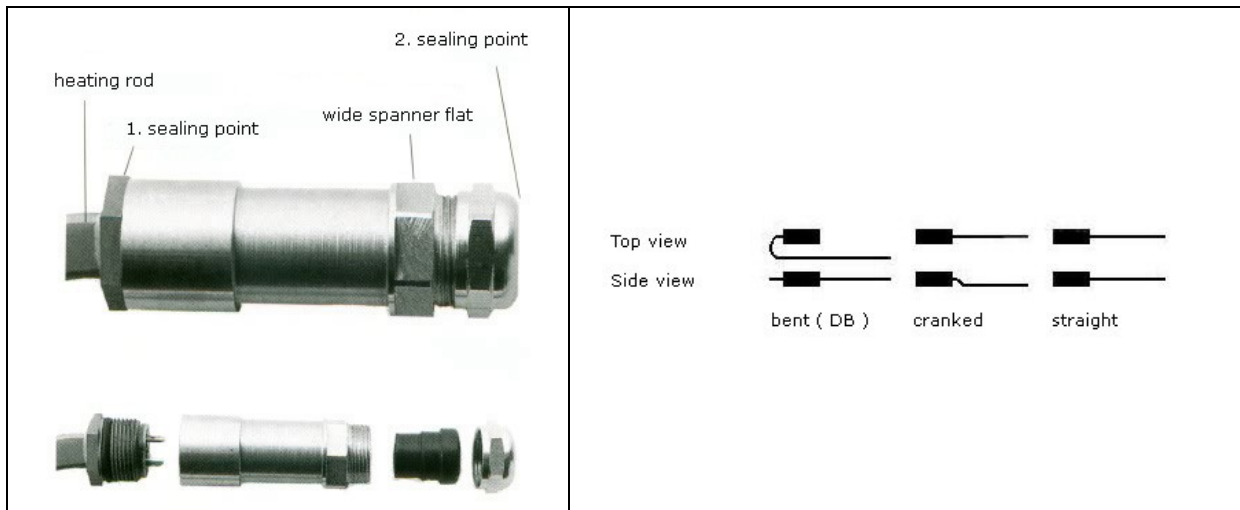

The absolute watertightness of the connecting heads made of chrome-nickel steel does not allow humidity or dirt to penetrate and the end of the heating element is waterproof filled up with synthetic resin.

We are CUSTOM MADE MANUFACTURERS, so do not hesitate to contact us for any SPECIAL FORMS, POWERS and LENGTHS(up to ca. 5900 mm) you may require.